

# **AES** **RAPTOR RESCUE™** PATENT PENDING

*Rescue Retrieval System*

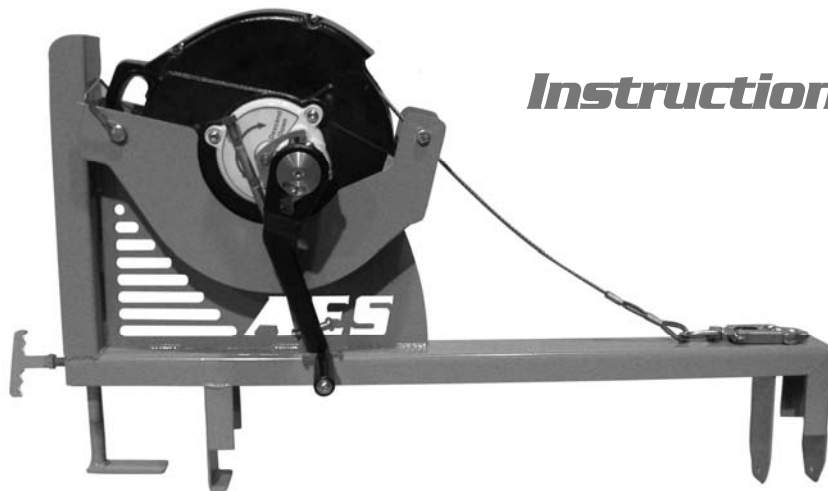

## *Instruction Manual*

ITEM NO: RMS-000-09

**\*WARNING\***

Serious injury or death may result if this product is used for purposes other than designed. The manufacturer provides the following instructions for the use and care of this equipment. It is the responsibility of the purchaser to understand and convey explicit instruction to each user. The AES Raptor Rescue™ complies with the requirements of the Federal Occupational Safety and Health Administration (OSHA) when set up and used according to the manufacturers' instructions.

**[WWW.RAPTORSAFETY.COM](http://WWW.RAPTORSAFETY.COM)**

# **AES RAPTOR RESCUE™ INSTRUCTION MANUAL**

**E  
N  
G  
L  
I  
S  
H**

## **AES Raptor, LLC - Raptor Rescue™ Instruction Manual**

Published by AES Raptor, LLC, North Kansas City, MO

**AES RAPTOR COMPLETE MOBILE FALL PROTECTION SYSTEM**  
is a registered trademark of  
Architectural Exterior Services CORPORATION MISSOURI  
1349 Taney  
North Kansas City MISSOURI 64116  
[www.raptorsafety.com](http://www.raptorsafety.com)

Copyright © 2009 by AES Raptor, LLC

PRINTED IN THE UNITED STATES OF AMERICA

# AES RAPTOR RESCUE™ INSTRUCTION MANUAL

## DIAGRAM OF PARTS

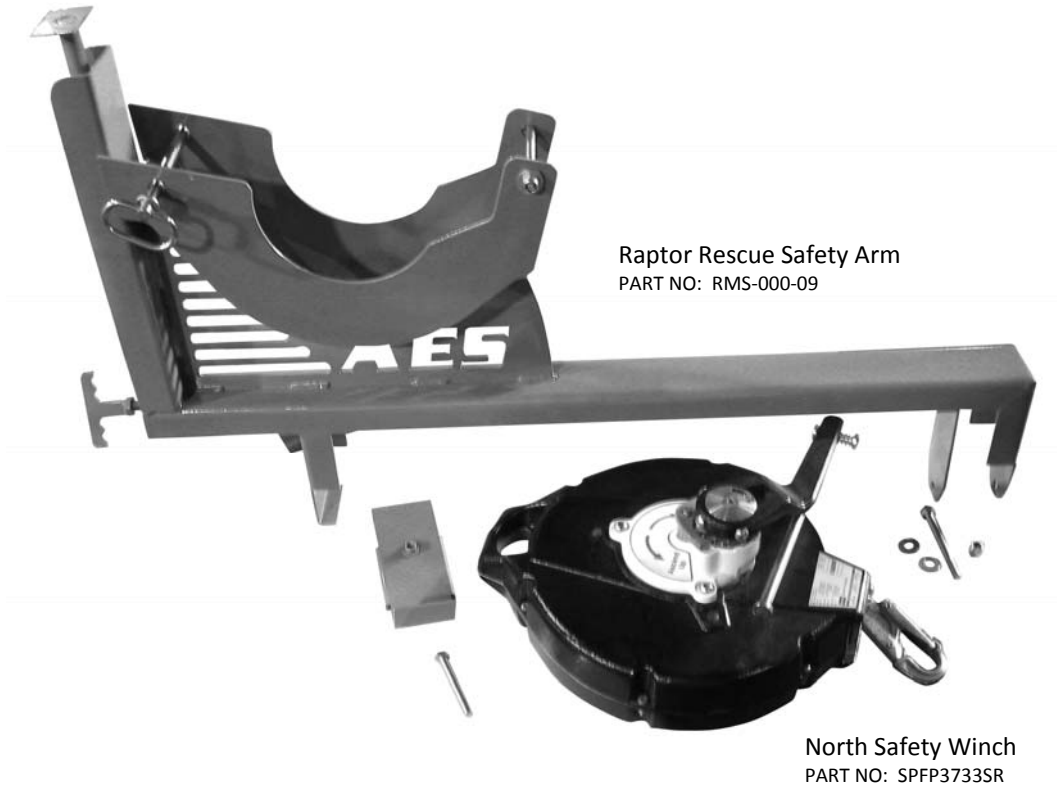

*Patent Pending*

## 1.0 ASSEMBLY / INSTALLATION

- 1.1 The Raptor Rescue System™ is designed to fit onto an existing or new R1000™ and TriRex™. Substitution or replacement with non-approved parts will void the testing and reliability of the entire rescue system.
- 1.2 Install the Raptor Rescue Safety Arm onto the R1000 or TriRex frame using the supplied fasteners (see Diagram 1).

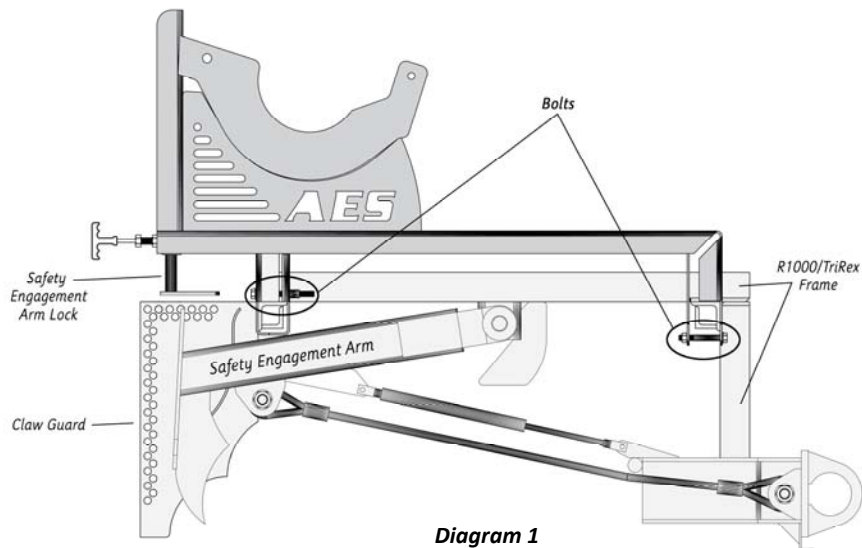

# AES RAPTOR RESCUE™ INSTRUCTION MANUAL

1.3 Install the North Safety Winch using the supplied pins (see Diagram2).

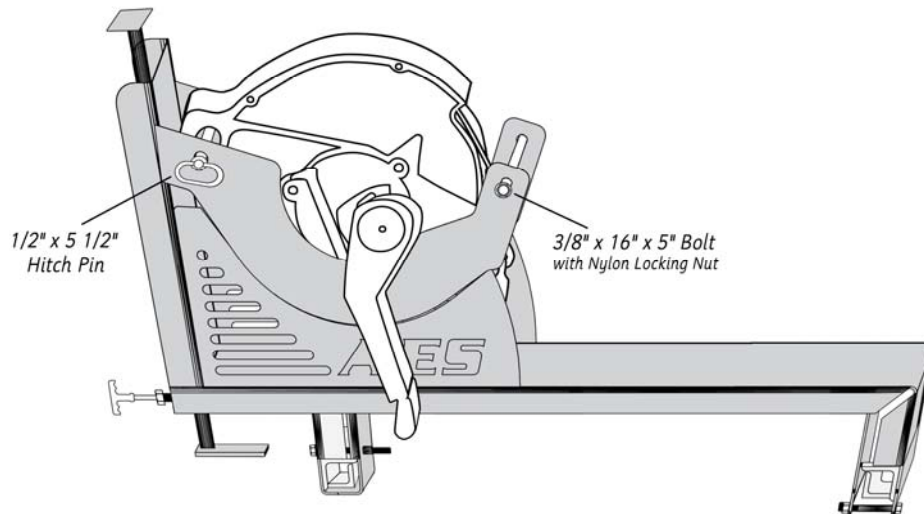

Diagram 2

## 2.0 APPLICATIONS

The Raptor Rescue Retrieval System is to be used for rescue of a fallen worker in conjunction with a R1000 or TriRes mobile fall protection cart. Warning – do not use the Raptor Rescue System with any other product not associated with AES Raptor LLC.

## 3.0 REGULATIONS

ANSI Z359.2-2007 states, “Employers shall develop and maintain written fall protection and rescue procedures for every location where an active fall protection system is used to control a fall hazard.” Furthermore, “The employer shall provide prompt rescue to all fallen authorized persons.”

OSHA also requires prompt rescue. OSHA 1910.66, subpart F, section 1(e)(8), states, “The employer shall provide for prompt rescue of employees in the event of a fall or shall assure the self-rescue capability of employees.” OSHA 1926.502 (d)(20) reads similarly.

Within ANSI Z359.2, the recommended contact time, defined as communication or physical contact, is less than 6 minutes, but it gives leeway on the definition of “prompt rescue” as dependent on the situation. Most consultants recommend full rescue within 5 minutes, and no longer than 15 minutes. An efficient rescue will take between 4 and 6 minutes, in which time physical or verbal contact with the victim must be made.

### DEFINITIONS:

- A. **Prompt Rescue** – Prompt rescue, as required under §1926.502(d)(20), is not defined in the standard. The particular hazard that §1926.502(d)(20) addresses is being suspended by the fall arrest system after a fall. While an employee may be safely suspended in a body harness for a longer period than from a body belt, the word "prompt" requires that rescue be performed quickly – in time to prevent serious injury to the worker.
- B. **Suspension Trauma** – (Syn. "orthostatic shock while suspended") [1], also known as Harness Hang Syndrome (HHS), or Orthostatic Incompetence is an effect which occurs when the human body is held upright without any movement for a period of time. If the person is strapped into a harness or tied to an upright object they will eventually suffer the Central Ischaemic Response (commonly known as fainting). If one faints but remains vertical, one risks death due to one's brain not receiving the oxygen it requires.

# AES RAPTOR RESCUE™ INSTRUCTION MANUAL

## 4.0 USE AND LIMITATIONS

### 4.1 PROCEDURES FOR RESCUE

- 4.1.1 Assess the Situation – the event that led to the fall may create additional risks that need to be addressed.
- 4.1.2 Make sure the rescue workers are protected against falling.
- 4.1.3 Lower the Safety engagement arm lock onto the engagement arm and lock into place (see Diagram 3).
- 4.1.4 Release the cable from the winch and lower it to the fallen worker.
- 4.1.5 Have the fallen worker hook the cable to his harness.
- 4.1.6 Raise or lower the fallen worker to safety.
- 4.1.7 Treat victim for Suspension Trauma and any other injuries.
- 4.1.8 Arrange for transportation to nearest hospital.

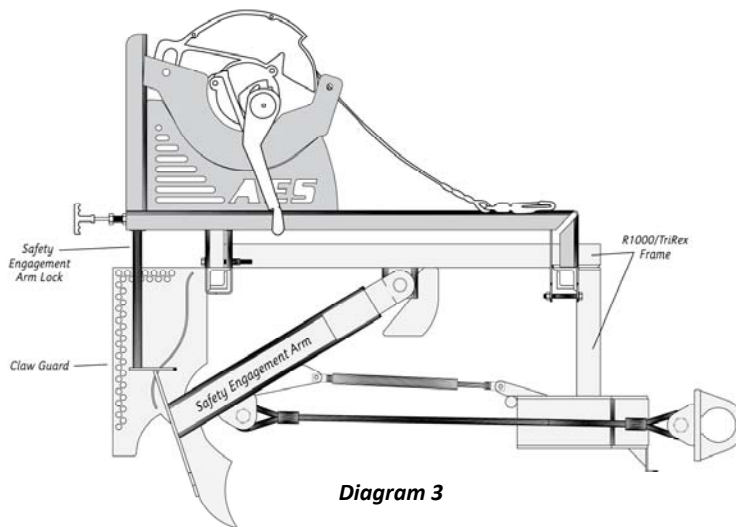

Diagram 3

**4.2 CAPACITY:** The Design working load limit is 350 lbs. Do Not Exceed Working Limits

**4.3 Do Not Use the Raptor Rescue System to Hoist Material – For Personnel use only**

## 5.0 BEFORE EACH USE:

5.0 OSHA 1926.502 requires that before operating the system there must be an inspection for damaged equipment.

### INSPECTION STEPS

- STEP 1: Check for loose, bent or damaged parts.
- STEP 2: Check welded connections for distortion, cracks, or other damage.
- STEP 3: Check cables for rusting and/or wear before each use – DO NOT use if cable and cable connections have been damaged.
- STEP 4: All labels must be present and fully legible. (Copies of all labels are attached at the back of the manual for accurate inspection)
- STEP 5: Check for corrosion on entire unit.

**DO NOT OPERATE DAMAGED EQUIPMENT.**  
**DO NOT OPERATE EQUIPMENT THAT HAS BEEN MODIFIED.**  
*(Please use the Inspection and Maintenance Log)*

## 6.0 GENERAL SAFETY

- 6.1 USE COMMON SENSE! Most accidents can be avoided by using common sense and concentrating on the job to be done.
- 6.2 The Raptor Rescue should not be used by persons whose ability or alertness is impaired by fatigue, intoxicating beverages, illegal or prescription drugs, or any other physical cause that exposes the user or others to injury.
- 6.3 Always wear proper safety attire.
- 6.4 Keep hands and feet clear of moving parts. DO NOT stick hands or fingers in the equipment when operating.



# AES RAPTOR RESCUE™ INSTRUCTION MANUAL

E  
N  
G  
L  
I  
S  
H

## APPENDIX A - WARNING LABELS

Upon each inspection please use this page to verify that both Warning Labels are present and fully legible.

 <b>WARNING</b>	 <b>ADVERTENCIA</b>	 <b>AVERTISSEMENT</b>
<b>BEFORE USE OF RESCUE SYSTEM LOWER ENGAGEMENT ARM LOCK</b> 	<b>BAJAR EL DISPOSITIVO DEL SEGURIDAD PARA ACOPLAMIENTO AL TECHO ANTES DE UTILIZAR PARA EL RESCATE</b> 	<b>AVANT D'UTILISER LE SYSTÈME DE SAUVETAGE, ABAISSER LE VERROU DU BRAS D'ENCLÈCHEMENT.</b> 

 <b>WARNING</b>	 <b>ADVERTENCIA</b>	 <b>AVERTISSEMENT</b>
<b>USE FOR PERSONNEL RESCUE ONLY</b>	<b>SOLAMENTE PARA EL PERSONAL DE RESCATE</b>	<b>UTILISER UNIQUEMENT À DES FINS DE SAUVETAGE DES PERSONNES</b>
<b>*NOT FOR MATERIAL HOISTING*</b>	<b>*NON ES PARA IZAR DE LOS MATERIALES*</b>	<b>* NON DESTINÉ AU LEVAGE DE MATÉRIEL *</b>

# AES RAPTOR RESCUE™ INSTRUCTION MANUAL

## APPENDIX B - ASSEMBLY, INSPECTION AND MAINTENANCE LOG

<b>DATE IN-SERVICE:</b>	
<b>ASSEMBLED BY: (PRINT NAME)</b>	
<b>SIGNATURE:</b>	
<b>COMPANY:</b>	
<b>INTENDED USE OR OTHER RELEVANT DETAILS:</b>	

\*\*\* PLEASE COPY THIS EXAMPLE LOG AND REVIEW BEFORE EACH USE AND DURING REGULARLY SCHEDULED MAINTENANCE \*\*\*

<b>DATE:</b>	
<b>INSPECTED BY:</b>	
<b>NOTE CONDITION OF:</b>	
<b>FRAME/ARM:</b>	
<b>WINCH:</b>	
<b>FASTENERS:</b>	
<b>NOTES:</b>	

<b>DATE:</b>	
<b>INSPECTED BY:</b>	
<b>NOTE CONDITION OF:</b>	
<b>FRAME/ARM:</b>	
<b>WINCH:</b>	
<b>FASTENERS:</b>	
<b>NOTES:</b>	

# AES RAPTOR RESCUE™ INSTRUCTION MANUAL



Copyright © 2009 by AES Raptor, LLC  
1349 Taney, North Kansas City MISSOURI 64116  
[www.raptorsafety.com](http://www.raptorsafety.com)

PRINTED IN THE UNITED STATES OF AMERICA