

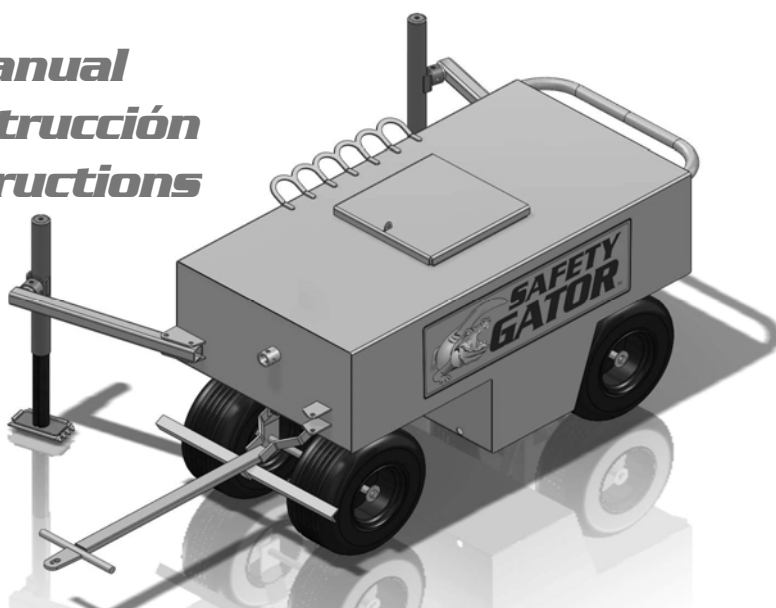

AES RAPTOR **SAFETY GATOR™** PATENT PENDING

Mobile Fall Protection System
Móvil Sistema de Protección Contra Caídas
Système de Protection Mobile Antichute

Instruction Manual **Manual de Instrucción** **Manuel d'Instructions**



WARNING

Serious injury or death may result if this product is used for purposes other than designed. The manufacturer provides the following instructions for the use and care of this equipment. It is the responsibility of the purchaser to understand and convey explicit instruction to each user. The SAFETY GATOR™ complies with the requirements of the Federal Occupational Safety and Health Administration (OSHA) when set up and used according to the manufacturers' instructions.

ADVERTENCIA

Si este producto se utiliza para otros fines que no son el de su diseño podría ocasionar daños graves o hasta la muerte. El fabricante provee las siguientes instrucciones para el uso y cuidado de este equipo. Es responsabilidad del comprador comprender y transmitir instrucciones explícitas a cada usuario. El SAFETY GATOR™ cumple con los requerimientos de la Federal Occupational Safety and Health Administration (OSHA) cuando se instala y se utiliza de acuerdo con las instrucciones del fabricante.

*** AVERTISSEMENT ***

L'utilisation de ce produit à d'autres fins que celles pour lesquelles il est conçu peut entraîner des blessures graves, voire mortelles. Le fabricant fournit les instructions suivantes pour l'utilisation et l'entretien de cet équipement. Il relève de la responsabilité de l'acheteur de comprendre et de transmettre les instructions explicites à chaque utilisateur. Le système SAFETY GATOR™ est conforme aux exigences de l'OSHA (Agence pour la sécurité et la santé au travail) lorsqu'il est installé et utilisé conformément aux instructions du fabricant.

AES SAFETY GATOR™ INSTRUCTION MANUAL

This Page Intentionally Left Blank.

AES SAFETY GATOR™ INSTRUCTION MANUAL

**E
N
G
L
I
S
H**

AES Raptor, LLC - SAFETY GATOR™ Instruction Manual

Published by AES Raptor, LLC, North Kansas City, MO

AES RAPTOR COMPLETE MOBILE FALL PROTECTION SYSTEM
is a registered trademark of
Architectural Exterior Services CORPORATION MISSOURI
1349 Taney
North Kansas City MISSOURI 64116
www.raptorsafety.com

Copyright © 2009 by AES Raptor, LLC

PRINTED IN THE UNITED STATES OF AMERICA

AES SAFETY GATOR™ INSTRUCTION MANUAL

2.0 APPLICATIONS

- 2.1 The Safety Gator Mobile Fall Protection cart is to be used as an anchorage point for a personal fall restraint system. The Safety Gator may be used where worker mobility and fall protection are required.
- 2.2 The Safety Gator is used as a part of a complete mobile fall protection system. Personal fall restraint systems typically include a full body harness, anchorage point, connectors, lifelines and rope grabs. See WWW.OSHA.GOV for all regulations and standards.
- 2.3 When set up properly the Safety Gator allows up to six workers to be tied off for fall restraint.

DEFINITIONS:

- A. **Fall Restraint System** – A fall protection system that prevents the user from falling any distance. The system is comprised of a body harness along with an anchorage, connectors and other necessary equipment. The components typically include a harness, lifeline and rope grab and also may include other devices.

3.0 USE AND LIMITATIONS

3.1 USE ON BUILDING GRADE ONLY

3.2 RECOMMENDED SURFACES INCLUDE:

1. Bare ground
2. Grass and lawns
3. Gravel
3. Concrete

3.3 DO NOT USE THE SAFETY GATOR ON THE FOLLOWING SURFACES:

1. Sloped roof
2. Flat roof
3. Unstable hillsides
4. Ice
5. Snow

**** BEFORE A SAFETY GATOR IS USED ****

**THE CONTRACTOR MUST VERIFY THAT THE SAFETY GATOR IS STABLE AND
WILL NOT ROLL OUT OF POSITION OR TURN OVER.**

- 3.4 **CAPACITY:** The Safety Gator Mobile Fall Protection System is designed for a maximum of six persons for fall restraint with a combined weight (clothing, tools) of no more than 310 lbs. per person. No more than six persons may be connected to the Safety Gator at any time.

AES SAFETY GATOR™ INSTRUCTION MANUAL

3.5 SET-UP

- A. First, determine the placement of the Safety Gator by pulling a line off the edge of the roof on a 30-45 degree angle to the tie-off rings on the unit.
- B. Make sure the Safety Lifeline Tie-off Rings are pointing toward the leading edge and the cart is set to parallel to the leading edge. Refer to the Illustration Below:

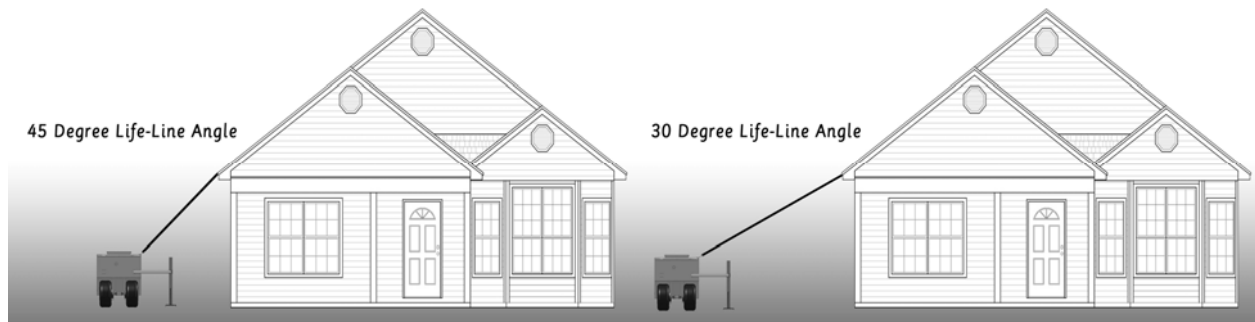

- C. Check to insure that the Safety Gator can be set as level as possible..
- D. Set both brake pins located on the rear axel. To set both pins it maybe necessary to tip the unit slightly and rotate a wheel to engage the Brake Lock Pin into each brake disk . Refer to the Illustration Below:

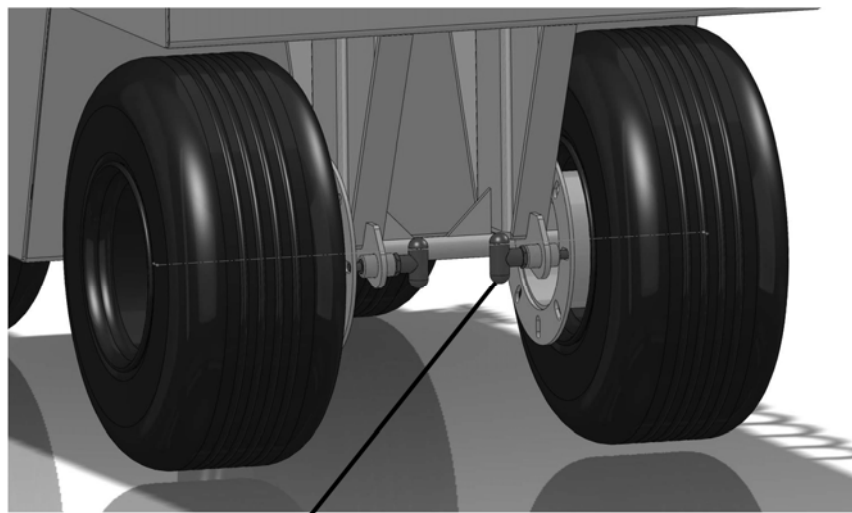

Spring Locking Brake Pins

- E. Remove the pins that attach the outrigger jacks to the unit.
- F. Swing the outrigger bars out and pin them in position towards the structure.
- G. Pin the jacks to the outrigger arms and set the jack base to touch the ground solidly.
- H. Verify that the units is positioned correctly and adjust if needed.

AES SAFETY GATOR™ INSTRUCTION MANUAL

E
N
G
L
I
S
H

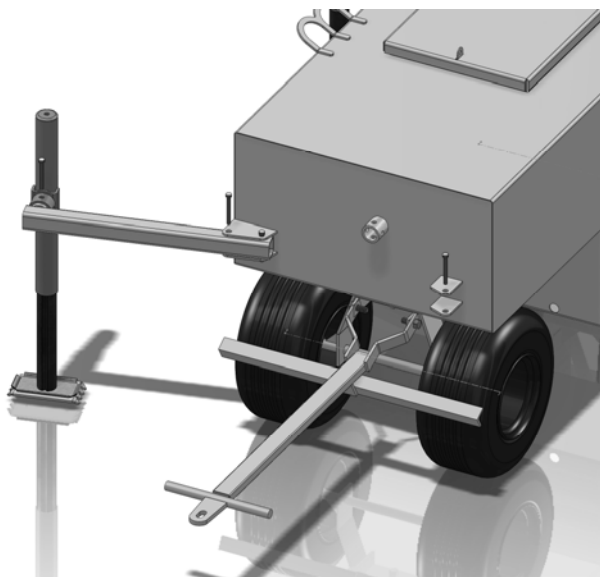

- I. Make sure the water drain valve is closed on the bottom of the unit and proceed to fill with water.
- J. Filling the unit usually takes 10-20 minutes. Fill times may vary depending on water pressures and volumes coming from different sources.
- K. Before proceeding make certain that the unit is filled to the appropriate level. Water level within 2" of the top is sufficient.
- L. Install the Ridge Safety line Guide and pass the safety lines, NO MORE THAN 6, thru the guide down to the Safety Gator and attach the lines to the Safety Tie-off Rings.



4.0 MAKING CONNECTIONS:

- 4.1 Only connect the Safety Tie-Off lines to the Tie-off Rings provided on the top of the Safety Gator. If the safety Tie-off rings are broken or damaged, remove from service immediately and contact AES Raptor, LLC at 1-888-990-2990.
- 4.2 DO NOT hook lifelines to any other locations on the cart – lifelines should only be hooked to the Safety Lifeline Tie-off Rings.
- 4.3 When making connections, only use self-locking snap hooks and self-locking carabiners with this equipment. Only use connectors that are suitable to each application. Ensure all connections are compatible in size, shape and strength. Do not use equipment that is not compatible. Ensure that all connectors are fully closed and locked.

5.0 BEFORE EACH USE:

- 5.1 OSHA 1926.502 requires that before operating the system there must be an inspection for damaged equipment.

INSPECTION STEPS

- STEP 1: Check for loose, bent or damaged parts.
- STEP 2: Check welded connections for distortion, cracks, or other damage.
- STEP 3: Check Tie-off-Rings for distortion or damage.
- STEP 4: Check Handle brake, and rear wheel Brake Pins, brackets and disks for any damage.
- S
- STEP 5: All labels must be present and fully legible. (Copies of all labels are attached at the back of this section for accurate inspection.)
- STEP 6: Check for corrosion on entire unit.
- STEP 7: Check for any holes that could cause water loss.
- STEP 8: Check Outrigger assembly to ensure it is not bent or damaged and all pins are installed correctly.

DO NOT OPERATE DAMAGED EQUIPMENT. DO NOT OPERATE EQUIPMENT THAT HAS BEEN MODIFIED.
(Please use the Inspection and Maintenance Log on page 10.)

6.0 MAINTENANCE AND CARE:

- A. Inspect all AES Raptor equipment and parts before and after each use.
- B. Keep wheels free from roofing debris.
- B. Regularly inspect all bolts and pins. Damaged or missing pins can severely hinder the safety factor of the Safety Gator.
- C. Maintain paint finish to prevent corrosion.

7.0 GENERAL SAFETY

- 7.1 USE COMMON SENSE! Most accidents can be avoided by using common sense and concentrating on the job to be done.
- 7.2 The AES Safety Gator should not be used by persons whose ability or alertness is impaired by fatigue, intoxicating beverages, illegal or prescription drugs, or any other physical cause that exposes the user or others to injury.
- 7.3 Always wear proper safety attire.
- 7.4 Keep hands and feet clear of moving parts. DO NOT stick hands or fingers in the equipment when operating.
- 7.5 Do not operate the equipment near electrical power lines.
- 7.6 Maintain proper and even tire pressure on cart tires if equipped with pneumatic tires.

AES SAFETY GATOR™ INSTRUCTION MANUAL

E
N
G
L
I
S
H

- 7.7 Do not allow passengers to ride on safety cart.
- 7.8 Allow handle to drop and set brake when not in use.
- 7.9 Ensure that the out riggers and jacks work properly. Make sure that all areas directly underneath, and in front of the cart, are clear and free of debris.
- 7.10 Do not use on icy conditions.
- 7.11 Only use the cart in a manner for which it has been tested.
- 7.12 Do not set cart on a steep sloped grade where the cart may slide or roll out of position.



AES SAFETY GATOR™ INSTRUCTION MANUAL

WARNING LABELS

Upon each inspection please use this page to verify that all six Warning Labels are present and fully legible.

 WARNING:	 ADVERTENCIA:	 AVERTISSEMENT
<p>This product is not designed for storing or transporting flammables, explosives, hazardous wastes or hazardous materials such as containers of solvents, gun powder, dynamite, gasoline, propane or acetylene tanks, etc.</p> <p>Any modification to or unintended use of this product could create a danger of an explosion or other hazardous condition that can result in death, serious injury or property damage.</p>	<p>Este producto no está diseñado para almacenar ni transportar materiales inflamables, explosivos, desperdicios o materiales peligrosos como contenedores de solventes, pólvora, dinamita, gasolina, tanques de propano o de acetileno, etc.</p> <p>Cualquier modificación que se haga a este producto o cualquier uso que se haga del mismo, que no sea el uso para el que se diseñó, podría crear un peligro de explosión u otra condición peligrosa que puede tener como resultado la muerte, las lesiones graves o los daños a la propiedad.</p>	<p>Ce produit n'est pas conçu pour stocker ou transporter des produits inflammables, des explosives, des déchets dangereux ou des matières dangereuses telles que des bidons de solvant, de la poudre explosive, de la dynamite, de l'essence, des réservoirs de propane ou d'acétylène, etc.</p> <p>Toute modification ou utilisation non prévue de ce produit peut créer un danger d'explosion et d'autres conditions dangereuses, pouvant entraîner la mort, des blessures graves ou des dommages matériels.</p>

(Located inside job box)

<p> WARNING: TO PREVENT BODILY INJURY</p> <p>OWNERS AND OPERATORS OF THIS EQUIPMENT SHOULD, PRIOR TO USING:</p> <p>Read the instruction manual. Read all warning labels. Know and comply with all OSHA, state and local regulations concerning roofing.</p>	<p>OWNER</p> <p>All employees should be instructed in the proper use of this equipment prior to use. If the employee cannot read or understand English, please provide a translator. This equipment should not be sold to, traded, or given to any other company or individual without instructing them in its proper use and without providing them with all instructions and warning labels.</p>
<p> ADVERTENCIA: PARA PREVENIR LAS LESIONES CORPORALES</p> <p>LOS DUEÑOS Y LOS OPERADORES DE ESTE EQUIPO DEBEN, ANTES DE UTILIZARLO:</p> <p>Leer el manual de instrucciones. Leer todos los rótulos de advertencia. Saber y cumplir todos los reglamentos de OSHA, así como los reglamentos locales y estatales relacionados con el techado</p>	<p>DUENO</p> <p>Todos los empleados deben recibir instrucción sobre el uso apropiado de este equipo antes de utilizarlo. Si el empleado no puede leer o entender inglés, por favor, proporcione un traductor. Este equipo no se debe vender, comerciar ni entregar a ninguna otra compañía o persona sin instruirle en el uso apropiado o sin proporcionarle todas las instrucciones y los rótulos de advertencia.</p>
<p> AVERTISSEMENT: POUR EVITER LES BLESSURES</p> <p>LES PROPRIÉTAIRES ET OPÉRATEURS DE CET ÉQUIPEMENT DOIVENT EFFECTUER LES ACTIONS SUIVANTES AVANT D'UTILISER LE PRODUIT:</p> <p>Lire le manuel d'instructions. Lire toutes les étiquettes d'avertissement. Connaître et respecter toutes les normes OSHA et les règlements locaux et provinciaux concernant les travaux de toiture</p>	<p>PROPRIÉTAIRE</p> <p>Tous les employés doivent être formés à l'utilisation appropriée de cet équipement avant de l'utiliser. Si l'employé ne peut pas lire ou comprendre l'français, un traducteur doit être fourni. Cet équipement ne doit pas être vendu, échangé, ni donné à une autre société ou à une autre personne sans les avoir préalablement formées à son utilisation correcte et sans leur avoir procuré toutes les instructions et étiquettes d'avertissement.</p>

(Located on back of the job box)

	CAUTION	PRECAUCIÓN	PRUDENCE
	PINCH POINT	PUNTO DE AGARRE	POINT DE PINCEMENT

(located by the tank lid)

AES SAFETY GATOR™ INSTRUCTION MANUAL



Raptor Inspection and Maintenance Log

PLEASE COPY THIS LOG, FILL IT OUT BEFORE EACH USE, AND KEEP IT IN YOUR RECORDS.

RAPTOR SERIAL #:			
RAPTOR MODEL #:			
DATE PURCHASED:			
INSPECTION DATE:			
Inspection Item Noted:	Corrective Action Needed?		Maintenance Performed:
	Yes	No	
Overall Cart Parts			
Approved By:			
Welded Connection	Yes	No	
Approved By:			
Safety Lifeline Tie-off Rings and Hoisting D-Rings	Yes	No	
Approved By:			
Cables	Yes	No	
Approved By:			
Labels	Yes	No	
Approved By:			
Overall Cart Corrosion	Yes	No	
Approved By:			

E
N
G
L
I
S
H

AES SAFETY GATOR™ INSTRUCTION MANUAL



Copyright © 2009 by AES Raptor, LLC
1349 Taney, North Kansas City MISSOURI 64116
www.raptorsafety.com

PRINTED IN THE UNITED STATES OF AMERICA